

External Transfer Switch application

Manual

Table of Contents

1. Introduction	1
1.1. Advantages	1
1.2. Compatibility	1
1.3. Hardware requirements	2
1.4. Grid code certification country list	3
2. Functionality	4
2.1. Single line diagram	4
3. Installation	5
3.1. AC voltage measurement	5
3.2. Current transformer	5
3.3. Ground relay	6
3.4. External transfer switch	6
3.5. Ziehl relay	7
4. Configuration	8
4.1. Upgrade to S99 VE.Bus firmware	8
4.2. VE.Bus System configuration	8
4.3. MultiPlus(-II) configuration	9
4.4. Venus OS version	10
4.5. GX device generator start/stop feature.	10
5. Troubleshooting	11
6. Wiring diagrams	12
6.1. General wiring diagram	12
6.2. Wiring diagram with added Ziehl relay	13

1. Introduction

This manual provides instructions for installing and configuring a system using an external transfer switch (contactor) instead of the built-in relays of the MultiPlus-II or the MultiPlus 20kW.

All compatible MultiPlus-II models including the MultiPlus 20kW are listed in the table below. This manual shall refer to this group as "MultiPlus(-II)".

This application significantly enhances the versatility, cost-effectiveness, and reliability of larger systems, particularly those of 60kVA and above.

1.1. Advantages

- **Reduce installation time and costs:** This reduces costs and installation time, especially for large systems with multiple MultiPlus(-II) units in parallel. It removes the need to wire each unit's AC input and output terminals.
- **Reduce equipment costs:** Combining MultiPlus-II 8, 10, or 15kVA units with an external transfer switch lifts their "no parallel" restriction. Otherwise, the more expensive Quattro 8, 10, or 15kVA units would have been required.
- **Flexible installation:** MultiPlus(-II) units and batteries can be placed up to 20 meters from the main distribution board without running power wiring back and forth.
- **No Bypass Switch Required:** Eliminates the need for a separate bypass switch.

1.2. Compatibility

See the table below for a list of MultiPlus and MultiPlus-II models which are supported by this application.

Ensure that the MultiPlus(-II) model number and the first four digits of the firmware number match the MultiPlus(-II) model that you intend to use.

You need to use a specific "External transfer switch firmware" with the s99 subversion number. These firmware files are available from <https://professional.victronenergy.com/downloads/firmware/>.

MultiPlus(-II) model	Firmware number
MultiPlus-II 48/6500/100-50	2602xxx-s99
MultiPlus-II 12/5000/220-50	2604xxx-s99
MultiPlus-II 24/5000/120-50 (+ EasySolar)	2615xxx-s99
MultiPlus-II 48/15000/200-100	2619xxx-s99 and 2684xxx-s99
MultiPlus-II 48/8000/110-100	2621xxx-s99
MultiPlus-II 48/5000/70-50 (ACOut2 switchable etc)	2623xxx-s99 and 2698xxx-s99
MultiPlus-II 48/10000/140-100	2627xxx-s99
MultiPlus-II 48/8000/110-100	2682xxx-s99
MultiPlus-II 48/10000/140-100	2683xxx-s99
MultiPlus 48/20000/250-100	2688xxx-s99
MultiPlus-II 24/5000/120-50	2696xxx-s99
MultiPlus-II 24/5000/120-95 120V (ACOut2 switchable etc)	2715xxx-s99
MultiPlus-II 48/5000/70-95 120V (ACOut2 switchable etc)	2723xxx-s99

Key specifications:

- **AC transfer rating:** 100 or 400A.
- **Unit limit:** Up to 12 MultiPlus(-II) units, with a maximum of 4 per phase.
- **System size:** Up to 180kVA using MultiPlus-II units, or 240kW using MultiPlus 20kW units.
- **AC input:** Supports only one AC input source.
- **AC input type:** Generator or grid AC input. For a full list of countries where grid connection is approved, see the [Grid code certification country list \[3\]](#) section.

- **Firmware:** Requires application-specific VE.Bus firmware, version s99.
- **Hardware:** Additional hardware is required; refer to the [Hardware requirements \[2\]](#) list.

1.3. Hardware requirements

- **External transfer switch:** Standard contactor.
- **Ground relay:** High current single-pole relay.
- **Ground help relay:** Low-power 230V relay with a 24V coil, enabling the MultiPlus(-II) low-power control signal to drive the high-power ground relay.
- **Victron Current Transformer(s):** One per phase, rated at 100 or 400A, for accurate current measurement and power management.
- **Four-pole circuit breakers and RCD:** For circuit protection.
- **Electrical wiring:** Refer to the [Installation \[5\]](#) chapter for detailed instructions.
- **Ziehl UFR1001E relay:** Required for certain grid-connected systems. Refer to the [Grid code certification country list \[3\]](#) to determine if it is necessary.

1.4. Grid code certification country list

The external transfer switch application has been tested and certified for grid-connected applications for the countries listed below.



Note that certain countries require the addition of a Ziehl UFR1001E relay, while others do not.

Country	Certificate*	Ziehl relay UFR1001E required
Austria	TOR Type A ver 1.3	-
Belgium	C10/11 ed 2.3	-
Denmark	TR3.3.1 Rev 5	-
Europe	EN50549-1:2019	Yes
Germany	VDE-AR-N 4105:2018:11	Yes
Northern Ireland	G99 Issue 1 Amd 1 (Dec 2023)	-
Poland	PTPiREE Rev 1.2:2021	-
South Africa	NRS 097-2-1:2024	Yes
Spain	UE2016/631 UNE217002:2020	-
United Kingdom	G99 Issue 1 Amd 10	-

*) The certificates can be accessed on our website.

MultiPlus-II: <https://www.victronenergy.com/inverters-chargers/multiplus-ii#downloads-certificates>

MultiPlus: <https://www.victronenergy.com/inverters-chargers/multiplus-12v-24v-48v-800va-3kva#downloads-certificates>

2. Functionality

The external transfer switch replaces the internal AC transfer switch of each individual MultiPlus(-II) unit in the system. The system operates almost identically to one using the internal AC transfer switches.

Features such as UPS functionality, AC input current limit, PowerControl, and PowerAssist remain active.

2.1. Single line diagram

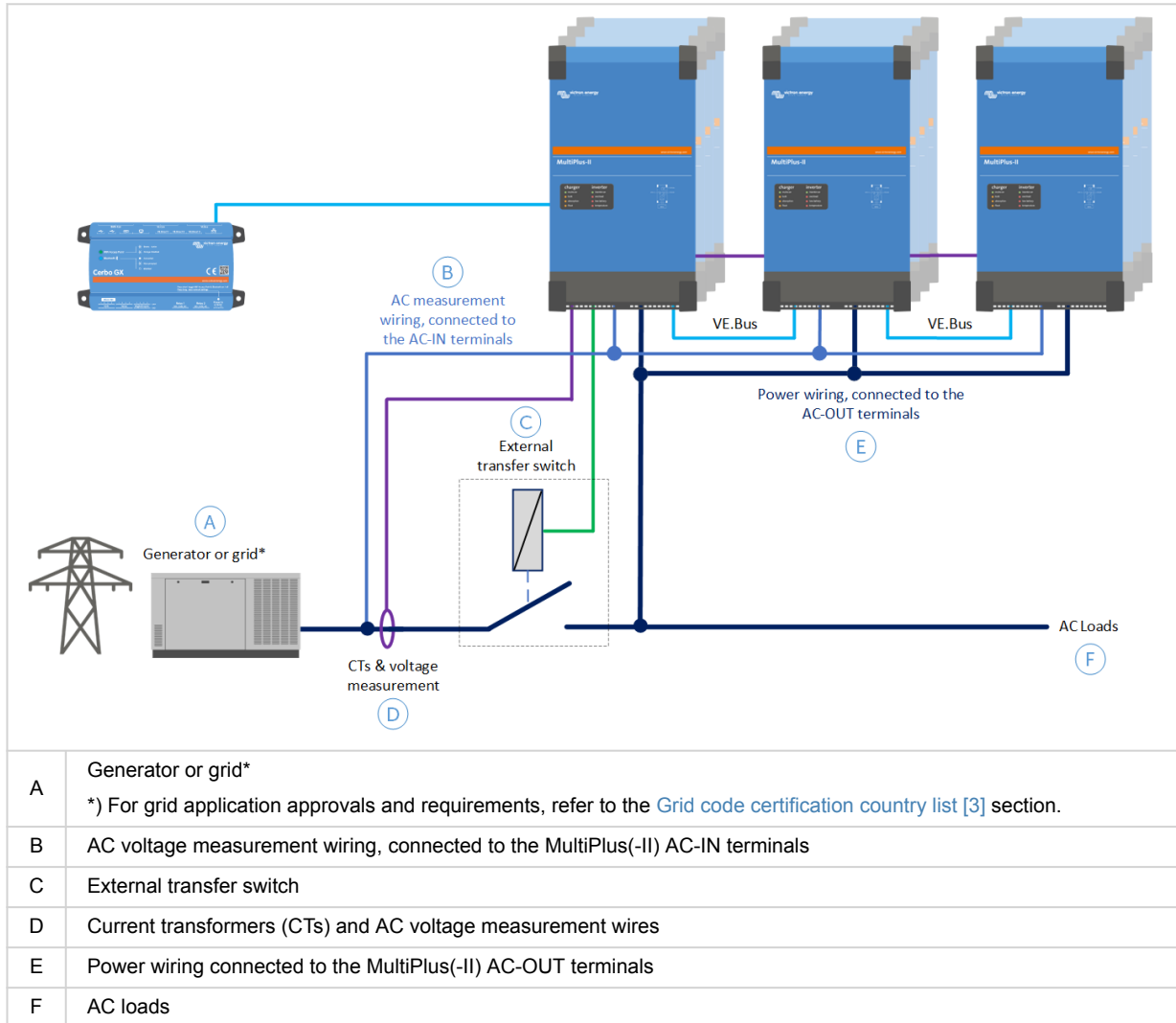

3. Installation

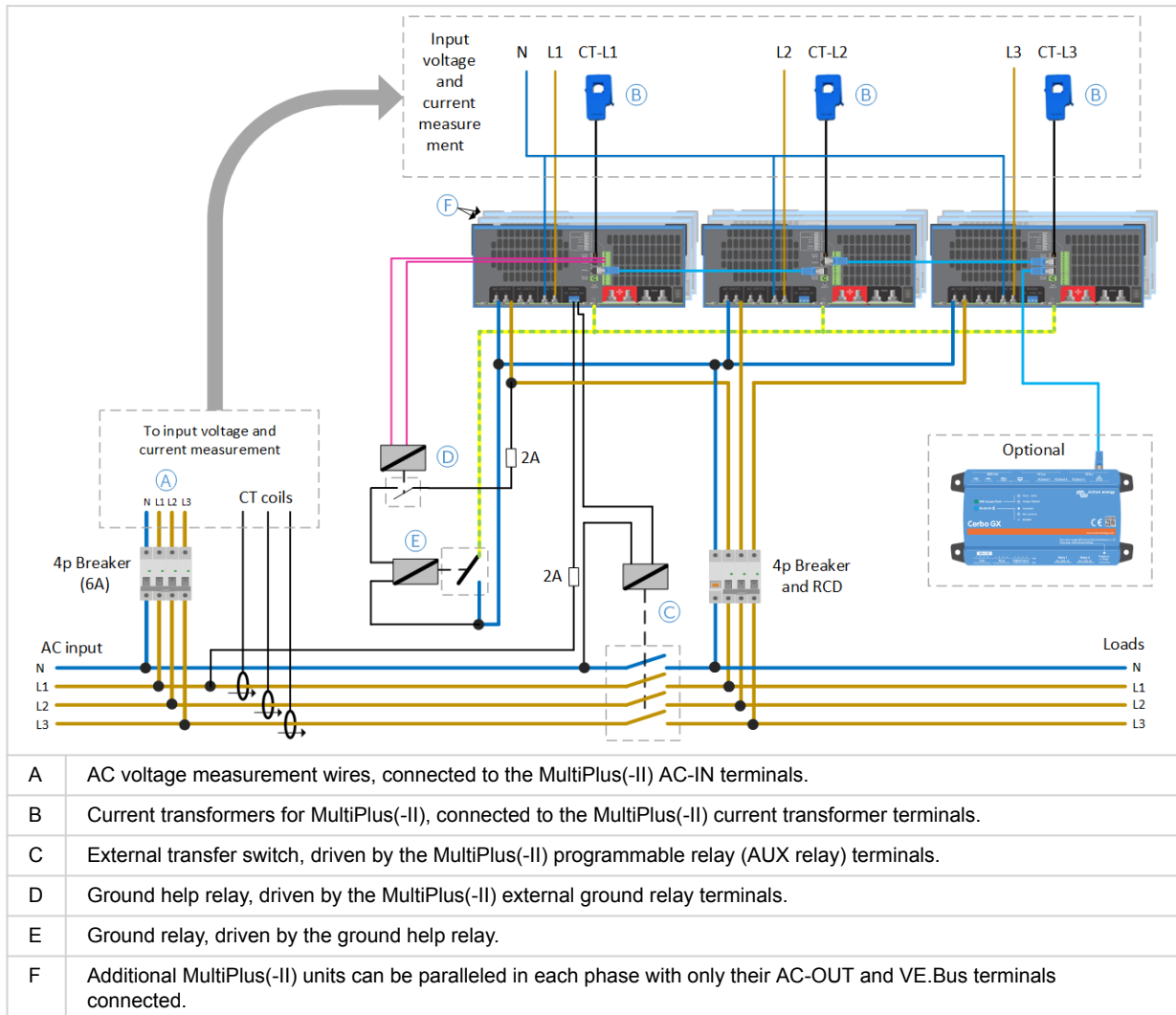

For the full-size diagram or the full-size diagram including a Ziehl UFR1001E relay, see the [Wiring diagrams \[12\]](#) section.



Parallel and multiphase systems are complex. We do not support or recommend untrained or inexperienced installers to work on these systems.

Before the system's initial power-up, double-check all wiring. Wiring mistakes can damage the MultiPlus(-II) units.

3.1. AC voltage measurement

The MultiPlus(-II) AC input functions as a measuring input. Since the internal back-feed relay is not used, the wires can be relatively thin, 1.5mm² wires are sufficient.

Connection procedure:

1. Connect the AC-IN terminals of MultiPlus(-II) to the AC supply.
2. For paralleled units, connect only the master unit (of each phase) to the AC-IN terminal and leave the slave units' AC-IN terminals unconnected.
3. Use a 6A four-pole circuit breaker to fuse the line and neutral wires.

3.2. Current transformer

The current transformers for each phase (L1, L2, and L3) are connected to the "Current Sense" inputs on the respective phase master MultiPlus(-II) units:

Connection procedure:

1. Remove the wire bridge between the INT and COM terminals.
2. Connect the red sensor wire to the EXT terminal and the white sensor wire to the COM terminal.
3. Ensure the wire direction through the current sensor follows the arrow pointing from the generator to the MultiPlus(-II).

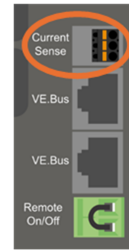
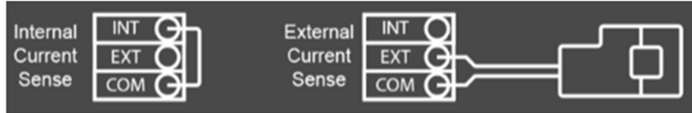

Important notes:

- Avoid routing current sensor wiring parallel and close to AC power wiring, signal wiring or VE.Bus wiring to prevent signal interference.
- The 400A current transformer has a reduced current sensing resolution, especially at low currents.

Compatible current transformers:

- **CRT12XXXXXX**: Current Transformer 100A:50mA for MultiPlus-II & MultiPlus 20kW Wire-end (available in 1.5 and 20m cable length).
- **CTR140050100**: Current Transformer 400A:50mA for MultiPlus-II & MultiPlus 20kW (10m) Wire-end (the current sensor wiring can be extended up to 20m using 0.75mm² wire).
- **CRT11XXXXXX**: Current Transformer 100A:50mA for MultiPlus-II Jack connector (for older MultiPlus-II units, available in 1.5 or 20m length).

For more information, see: <https://www.victronenergy.com/meters-and-sensors/current-transformer-for-multiplus-ii>.

3.3. Ground relay

The ground relay drive signal is supplied by the MultiPlus(-II) "Ext GND Relay" terminals of the L1 phase master unit via a help relay.

Since the "Ext GND Relay" output signal is limited to 24V / 200mA, a help relay with a 24V coil must be used to switch the actual ground relay.

The ground relay rating must match the total inverter power of the system.

Connection procedure:

1. Connect the help relay coil terminals to the MultiPlus(-II) "Ext. GND Relay" terminals.
2. Connect the help relay power terminals to L1 MultiPlus(-II) AC-OUT L terminal and one of the Ground relay coil terminals. Fuse this wire with a 2A fuse.
3. Connect the remaining ground relay coil terminal to the L1 MultiPlus(-II) AC-OUT N terminal.
4. Connect the ground relay power terminals between The MultiPlus(-II) GND and AC-OUT N terminals.

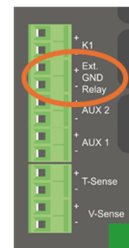

3.4. External transfer switch

Any standard contactor can be used.

Since inverter current flows through the AC outputs of the MultiPlus(-II) units, ensure the external transfer contactor wiring is appropriately sized and symmetrical.

Connection procedure:

1. Connect the contactor coil directly to the NO and COM terminals of the MultiPlus(-II) "AUX RELAY" terminals of the L1 phase master unit. Fuse this wire with a 2A fuse.
2. Connect one side of the contactor power terminals to the AC supply.
3. Connect the other side of the contactor power terminals to the AC-OUT terminals or the MultiPlus(-II) units and the AC loads.
4. Protect the AC output wiring with a circuit breaker suitable for the expected load and wire gauge. Fuse both line and neutral wiring.

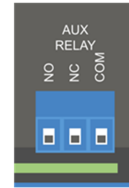

3.5. Ziehl relay

A Ziehl UFR1001E relay might be required for certain grid-connected countries or applications. The [Grid code certification country list \[3\]](#) section lists the requirements per country.

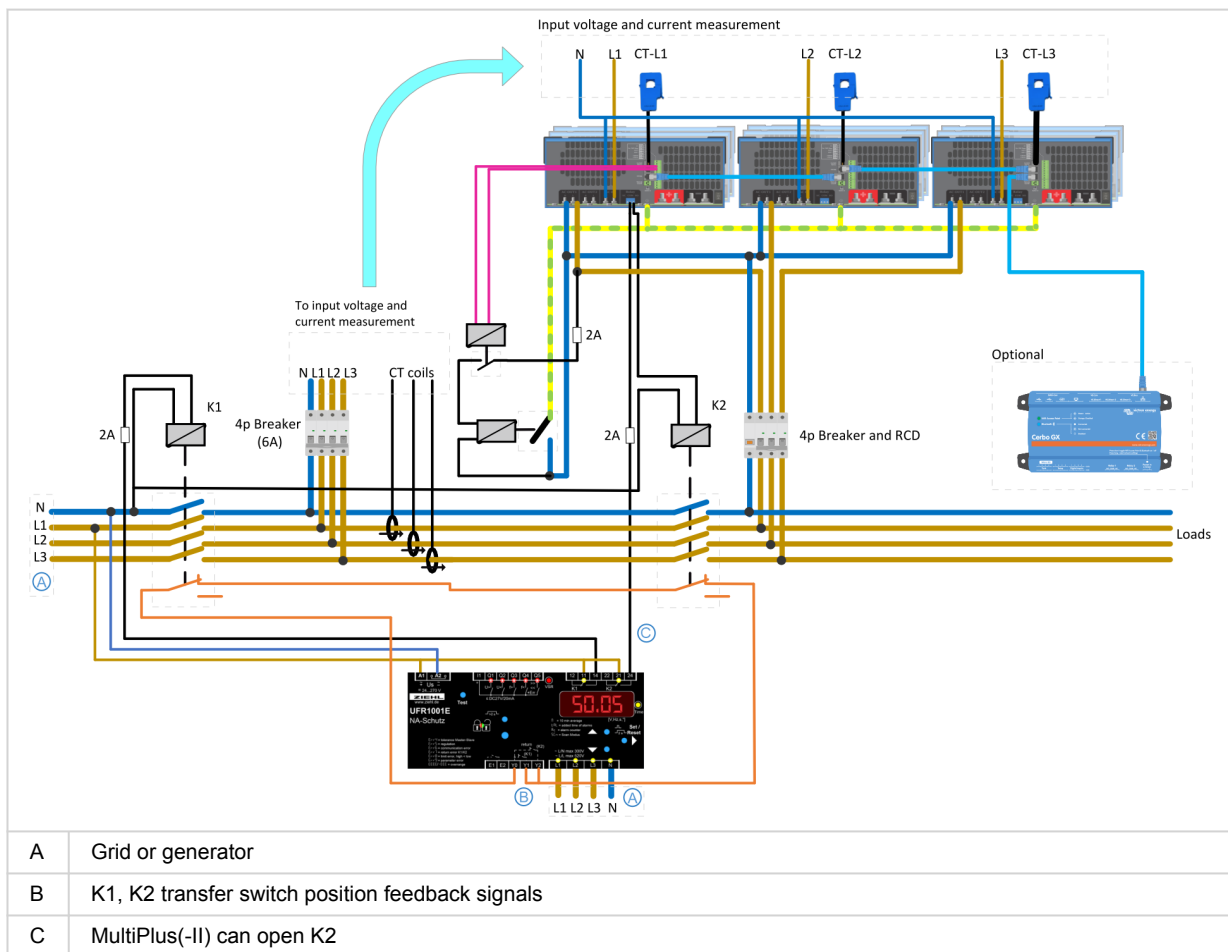

For more information on the Ziehl UFR1001E relay, visit our website: <https://www.victronenergy.com/accessories/ziehl-voltage-frequency-sensitive-relay-ufr1001e>

For the full wiring diagram, see the [Wiring diagram with added Ziehl relay \[13\]](#) section.

4. Configuration

4.1. Upgrade to S99 VE.Bus firmware

The MultiPlus(-II) units require application-specific VE.Bus firmware, identified by the ".S99" subversion number.

Upgrade procedure:

1. Download the xxxyy.S99.vff file from <https://professional.victronenergy.com/>
2. Install the firmware using VEFash, the VictronConnect app, or the VRM Portal.
3. Ensure you select the xxxyy.S99.vff file during the firmware upgrade.
4. Repeat the process for all MultiPlus(-II) units.



CAUTION: Never use MultiPlus(-II) unit with standard firmware in an "External transfer switch" application. This will cause the system to connect to the AC input and likely trigger the current protection on that measurement-only circuit.

4.2. VE.Bus System configuration

Use the "VE.Bus System Configurator" to set up the system.

Configuration procedure

1. Configure all phase masters in AC input group 1.
2. Configure all slaves in AC Input Group 2.

Refer to the following screenshots.

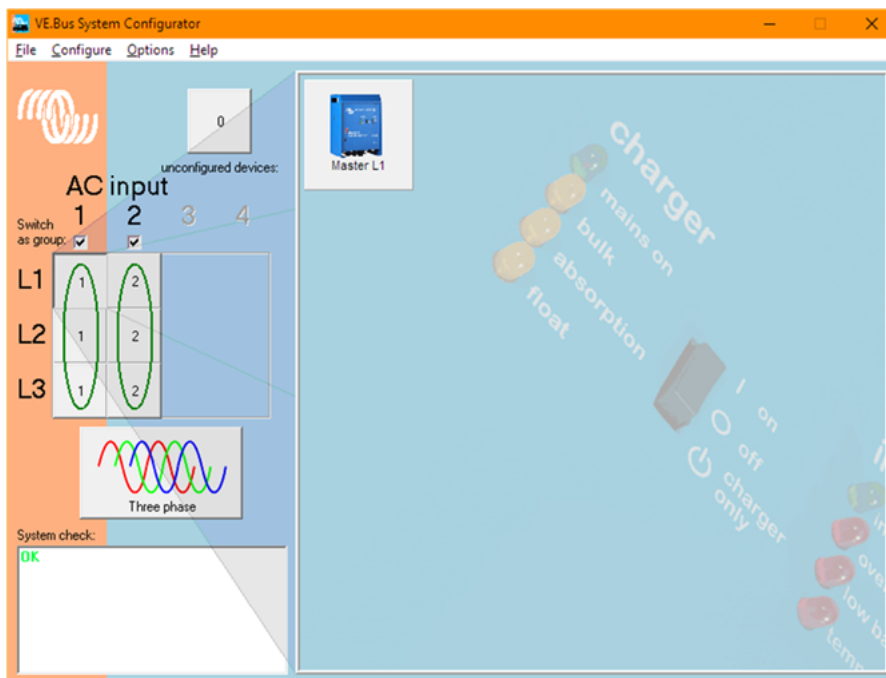

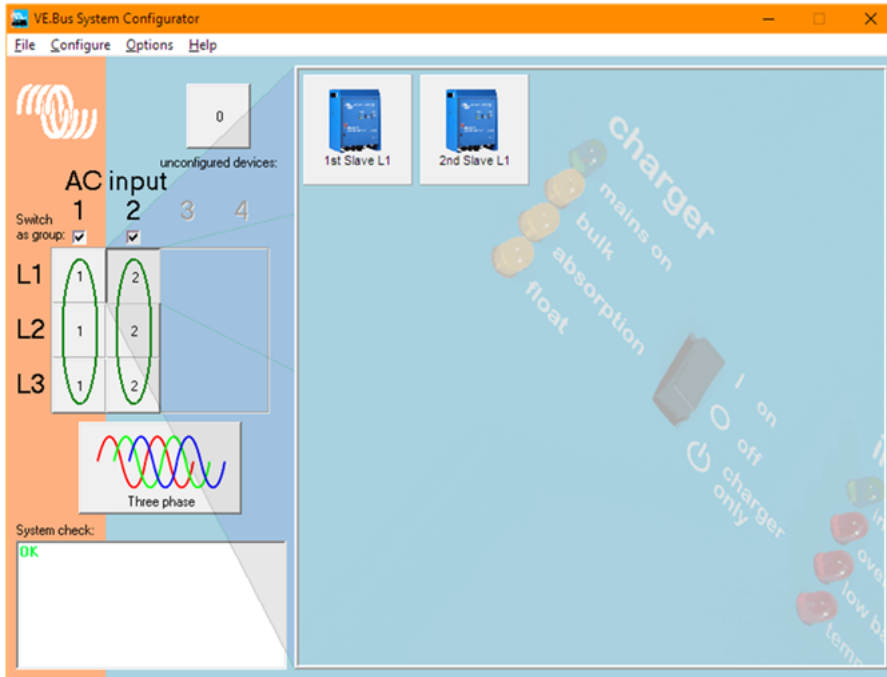

4.3. MultiPlus(-II) configuration

Use "VEConfigure" to configure each MultiPlus(-II) unit.

Configuration procedure:

1. Ensure the "S99" firmware version is installed
2. Navigate to the "General" tab.
3. For all phase master and slave units, set the "Current sensor rating" to 100 or 400A, matching the current sensor's current rating.
4. Navigate to the "Grid" tab.
5. For all units, set the grid code as required. For off-grid, select "None", and for grid connect, select the applicable grid code.

Refer to the following screenshot.

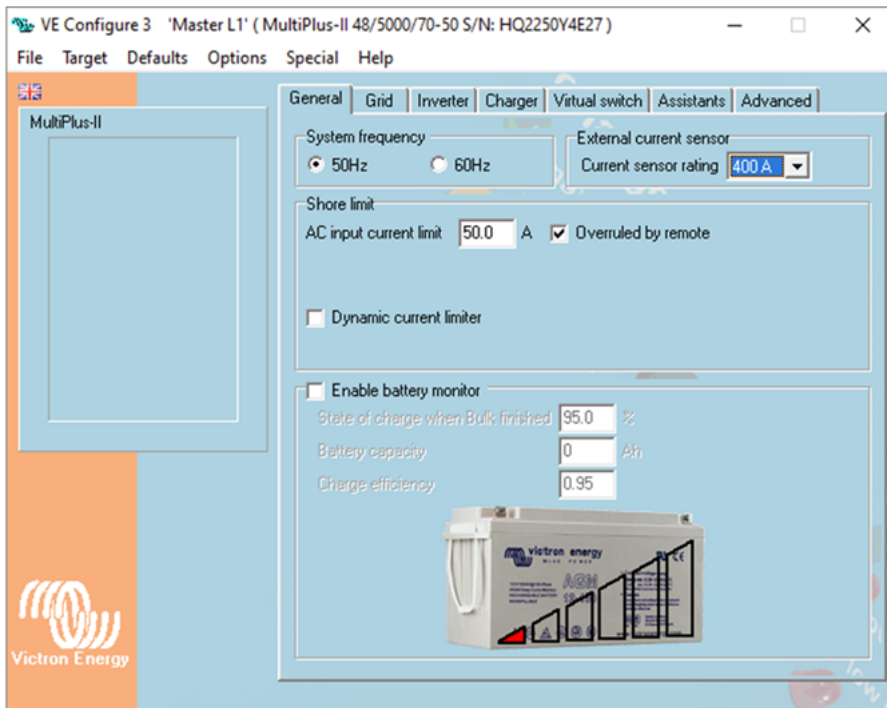

4.4. Venus OS version

If a GX device is used, it should be updated to Venus OS version 3.33 or later.

4.5. GX device generator start/stop feature.

If the system includes a generator, we recommend using the generator start/stop feature in our GX devices, including the cool-down function, to ensure a seamless transfer.

Here is how it works:

When the system receives the signal to stop the generator, the inverter first takes over the load. Only after this and after the configured cool-down period will the generator stop. This makes the exact opening time of the contactor irrelevant, ensuring an instant (0 ms) transfer with no interruption.

In contrast, stopping the generator first and allowing the inverter to initiate the transfer after it has detected a drop in voltage or frequency will result in a slower changeover, regardless of contactor speed.

For more details on the GX generator start/stop feature and integration with DSE, ComAp, and other generator controllers, see [Chapter 17 of the GX manual](#).

5. Troubleshooting

General troubleshooting

If the system exhibits strange behaviour, check the following:

- **Current sensor orientation:** Ensure that the current transformers (CTs) are correctly oriented. The arrow on the CT should point from the grid or generator to the contactor, following the direction indicated in the [Wiring diagrams \[12\]](#) chapter.
- **Current sensor connections:** Verify that the current sensors are connected to the correct units: L1 to the L1 unit, L2 to the L2 unit, and so on.
- **Wiring placement:** Ensure the current sensor wires are not routed too close to AC or signal wires.

Inverter/charger connection Issues

The inverter/chargers fail to connect to the grid or generator:

- Check whether the AC-In terminals on slave units are wired. They should **not** be wired.

The system status is unknown, and inverter/chargers are inverting:

- Check whether the AC-In terminals on slave units are wired. They should **not** be wired.

The inverter/chargers will not switch on, and all charge status LEDs are flashing:

- This indicates a configuration fault. Verify that the current transformer (CT) rating matches the system capacity.
For example, in a three-phase 12 x 48/15000 MultiPlus-II setup, this fault occurs if the configured CT rating is set to 100A. For such a system, a 400A CT rating is required.

Constraints

- The programmable relays on L2, L3, and all slave units **cannot** be used.
- The VictronConnect app cannot be used for system configuration and current sensor settings. Use **VEConfigure 3** and **VE.Bus System Configurator** software instead.

6. Wiring diagrams

6.1. General wiring diagram

An example of a general wiring diagram using MultiPlus-II units.

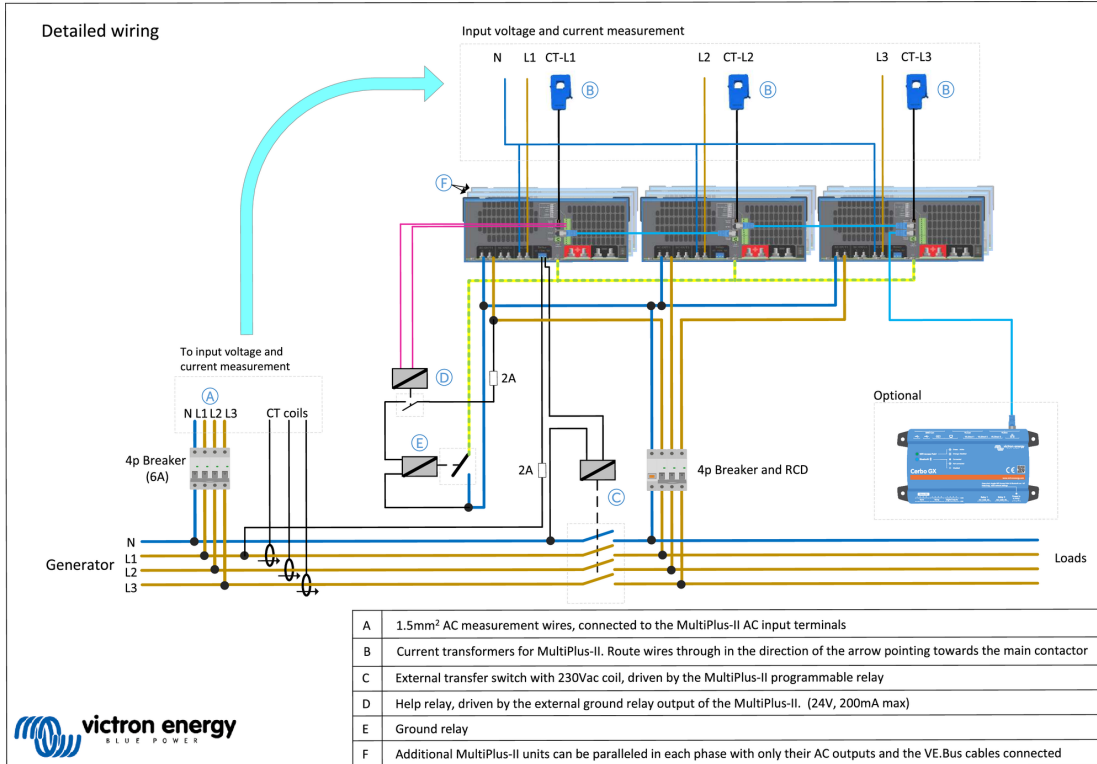

6.2. Wiring diagram with added Ziehl relay

This diagram is an example using a Ziehl relay and MultiPlus-II units.

